

» ZYD Vibrating Screen

Functional principle

Its vertical motor, which is installed eccentric hammers on the top and bottom, is regarded as a vibratory source. The eccentric hammers change rotation into horizontal, vertical and inclined movement, and then pass the movement to the sieving surface. Adjusting the phase angle on the top and bottom can change trajectories of the materials on the sieve.

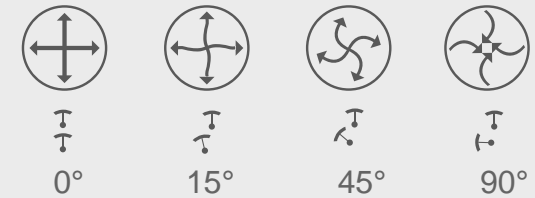

Material trajectory

Description

We adopt new type dynamic generator, making three dimension powers more obviously and successfully, making the scale of processed materials enlarged. Accordingly this makes ZYD vibratory screen capable of processing various kinds of materials.

Application

Various kinds of the materials can be screened by the machines including those within 0~400mesh like dry, wet, refined, coarse, heavy and light as well as those within 0~600mesh like liquid and pasty materials.

Product Feature

1 High efficiency

High efficiency, ingenious design, durable and suitable for screening any kinds of the powder and viscous fluid.

2 Fully sealed structure

No jam for the screen net, no powders flying around and no liquid leaking out when running, fully sealed structure and environmentally friendly.

3 Small size

Small size and can be moved easily.

4 Uniquely designed

The screen nets are uniquely designed under 500 mesh, and the net.

5 Facilitate clean

It only takes 3~5 MINS to replace and clean the net conveniently.

6 Stainless steel

Stainless steel parts contacting materials.

7 Easy to operate

Easy to operate, impurities and coarse materials can be discharged automatically, continuous operations.



Fitting

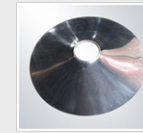

dust cover



middle frame



bottom frame



net rack



clamp ring



clamp ring screws



U-shaped sealing ring



V-shaped sealing ring



Rubber ball



Punching board



Net rack combination



PU ring and rubber balls



Silicone ball



Silicone sealing ring



Screen



Spring

ZYD Vibrating Screen Structure Illustration

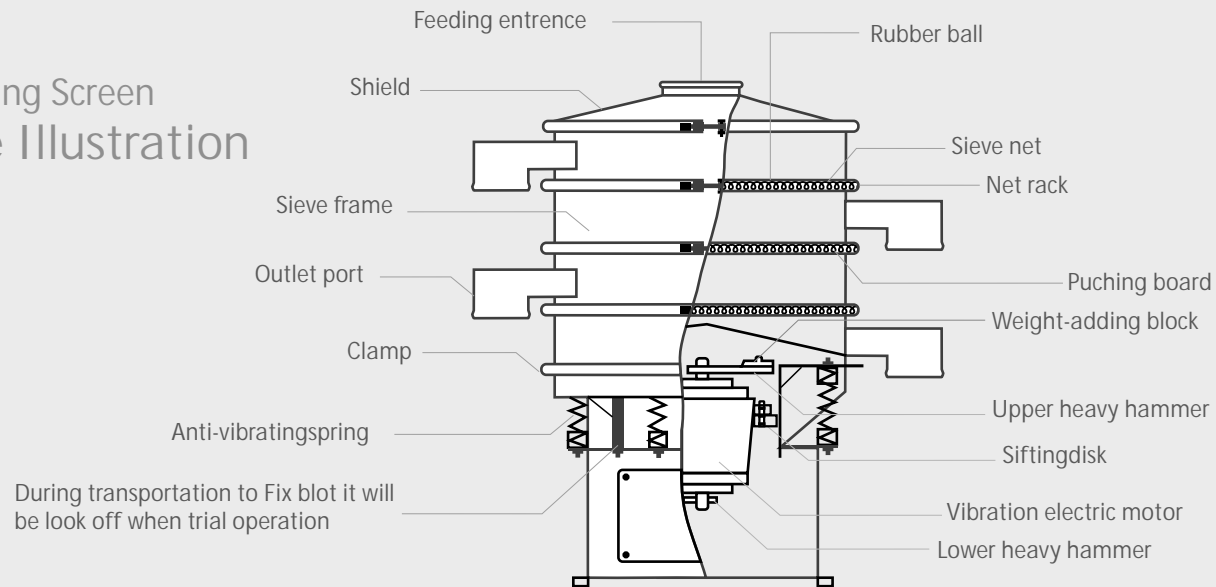

Technical Parameters

1S				580×580×560	1
ZYD-400-2S	0.18	320		580×580×660	2
3S				580×580×760	3
1S					800×800×680
ZYD-600-2S	0.25	550		800×800×780	2
3S				800×800×880	3
1S					900×900×780
ZYD-800-2S	0.55	750		900×900×930	2
3S				900×900×1080	3
1S					1160×1160×880
ZYD-1000-2S	0.75	950		1160×1160×1030	2
3S				1160×1160×1180	3
1S					1360×1360×980
ZYD-1200-2S	1.1	1150		1360×1360×1160	2
3S				1360×1360×1360	3
1S					1850×1850×1130
ZYD-1500-2S	1.5	1450		1850×1850×1330	2
3S				1850×1850×1550	3
1S					2200×2200×1360
ZYD-1800-2S	2.2	1750		2200×2200×1460	2
3S				2200×2200×1680	3



ZYD Vibrating Screen Size Indication

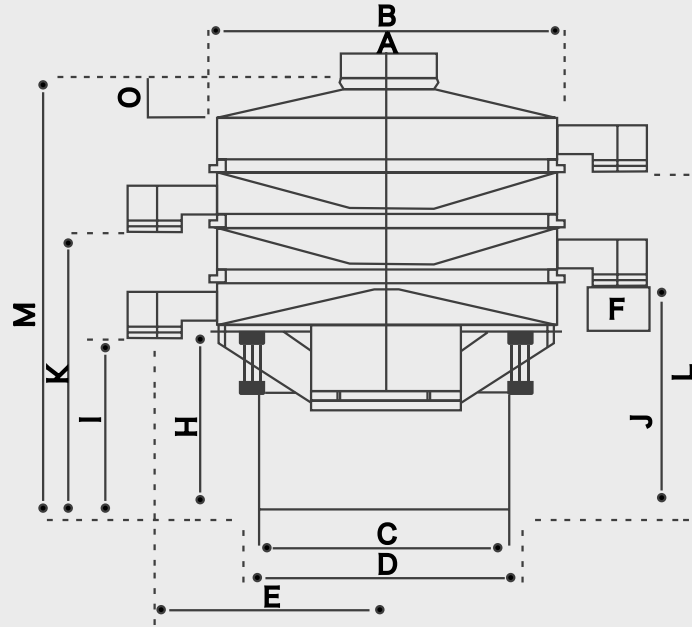

Size Instruction

ZYD-400-1S	150	400	358	408	310	100	75	249	257	367		558	
ZYD-400-2S	150	400	358	408	310	100	75	249	257	367	477	668	
ZYD-600-1S	150	600	426	476	410	100	75	354	362	472		668	
ZYD-600-2S	150	600	426	476	410	100	75	354	362	472	582	778	
ZYD-600-3S	150	600	426	476	410	100	75	354	362	472	582	692	886
ZYD-800-1S	200	800	580	630	530	125	100	404	412	557		798	
ZYD-800-2S	200	800	580	630	530	125	100	404	412	557	702	943	
ZYD-800-3S	200	800	580	630	530	125	100	404	412	557	702	847	1088
ZYD-1000-1S	250	970	700	750	640	150	120	466	475	620		880	
ZYD-1000-2S	250	970	700	750	640	150	120	466	475	620	765	1025	
ZYD-1000-3S	250	970	700	750	640	150	120	466	475	620	765	910	1170
ZYD-1200-1S	250	1170	855	920	750	180	140	570	595	760		1045	
ZYD-1200-2S	250	1170	855	920	750	180	140	570	595	760	925	1210	
ZYD-1200-3S	250	1170	855	920	750	180	140	570	595	760	925	1090	1375
ZYD-1500-1S	250	1470	1050	1120	960	200	170	530	555	750		1090	
ZYD-1500-2S	250	1470	1050	1120	960	200	170	530	555	750	945	1285	
ZYD-1500-3S	250	1470	1050	1120	960	200	170	530	555	750	945	1040	1480
ZYD-1800-1S	300	1770	1360	1430	1030	200	200	618	640	835		1226	
ZYD-1800-2S	300	1770	1360	1430	1030	200	200	618	640	835	1030	1420	
ZYD-1800-3S	300	1770	1360	1430	1030	200	200	618	640	835	1030	1225	1615

